

Distributed Vending Machine

Team 5 / OOPT Stage 2040

5조

201711310 변건우

202011313 손윤환

202014186 오상희

201912698 이현규

CONTENTS

2041	Design Real Use Cases
2042	Define Reports, UI, and Storyboards
2043	Refine System Architecture
2044	Define Sequence Diagrams
2045	Define Design Class Diagrams
2046	Design Traceability Analysis

2041 Design Real Use Cases

Use Case	1. Select mode
Actor	User, Manager
Purpose	자판기 사용 모드를 선택한다.
Overview	음료 선택, 선결제 수령, 매니저 3가지 모드를 선택할 수 있다.
Type	Evident
Cross Reference	Functions: R1.1 Use Cases: 3. Select Item 12.Read Manager Authentication code, 12.Read Manager Authentication code
Pre-Requisites	Set up
Typical Courses of Events	(U):User, (M): Manager, (S): System, (O): other vm 1.1 (U): 음료를 선택한다 1.2 (S): Show menu를 실행한다. 2.1 (U): 선결제 수령을 실행한다. 2.2 (S): Read authentication code를 실행한다. 3.1 (M): 매니저 모드를 실행한다. 3.2 (S): Manage stock을 실행한다.
Alternative Courses of Events	N/A
Exceptional Courses of Events	N/A

2041 Design Real Use Cases

Use Case	2. Set up
Actor	None
Purpose	자판기를 초기 설정한다.
Overview	자판기 사용에 필요한 초기 값들을 설정한다.
Type	Event
Cross Reference	Functions: R1.2 Use Cases: 12.Read Manager Authentication code
Pre-Requisites	N/A
Typical Courses of Events	(U):User, (M): Manager, (S): System, (O): other vm <ol style="list-style-type: none"> 1. (M): (O)의 id값을 등록한다. 2. (M): manager id를 등록한다. 3. (M): 카드번호와 카드잔고를 입력한다. 4. (M): 음료코드와 음료 개수를 입력한다. 5. (M): select mode를 수행한다.
Alternative Courses of Events	N/A
Exceptional Courses of Events	N/A

2041 Design Real Use Cases

Use Case	3. Select item
Actor	User
Purpose	User가 원하는 음료수(item)을 선택한다.
Overview	User가 VM에서 보여주는 메뉴에서 원하는 음료수를 선택한다.
Type	Evident
Cross Reference	Functions: R 1.3 Use Cases: 5. Check item stock 3. Select Item
Pre-Requisites	1.음료 선택이 선택된다.(1. Select mode)
Typical Courses of Events	(U):User, (M): Manager, (S): System, (O): other vm 1. (U): 구매하고자 하는 음료와 개수를 선택한다. 2. (S): check item stock을 실행한다.
Alternative Courses of Events	N/A
Exceptional Courses of Events	N/A

2041 Design Real Use Cases

Use Case	4. msg Request
Actor	None
Purpose	다른 자판기들에게 요청을 보낸다.
Overview	다른 자판기들에게 현재 자판기에서 내용과 함께 요청을 보낸다.
Type	Hidden
Cross Reference	Functions: R 2.1 Use Cases: 6. msg Return
Pre-Requisites	요청할 메시지의 내용
Typical Courses of Events	(U):User, (M): Manager, (S): System, (O): other vm 1. (S): msgRequest 타입에 맞는 요청을 찾는다. 2. (S): 해당 요청에 필요한 인자와 함께 (O)에 msgRequest를 요청한다.
Alternative Courses of Events	N/A
Exceptional Courses of Events	N/A

2041 Design Real Use Cases

Use Case	5. msg Return
Actor	None
Purpose	요청에 응답한다.
Overview	msg Request에 의해 전달받은 내용을 확인 후 응답한다.
Type	Evident
Cross Reference	Functions: R 2.2 Use Cases: 5. msg Request
Pre-Requisites	msg Request를 통해 요청을 받는다.
Typical Courses of Events	(U):User, (M): Manager, (S): System, (O): other vm 1.(O): 전달받은 msg 타입과 내용을 확인한다. 2.(O): 확인한 내용을 수행후 결과를 반환한다.
Alternative Courses of Events	N/A
Exceptional Courses of Events	N/A

2041 Design Real Use Cases

Use Case	6. Normal payment
Actor	None
Purpose	일반결제를 진행한다.
Overview	일반결제를 진행한다.
Type	Evident
Cross Reference	Functions: R 3.1 Use Cases: 3. Select Item
Pre-Requisites	check item stock에서 재고가 존재한다.
Typical Courses of Events	(U): User, (M): Manager, (S): System, (O): other vm 1. (S): card번호를 요청한다. 2. (U): card번호를 입력한다. 3. (S): card번호로 계산을 수행한다 4. (S): 계산이 성공인 경우 item out을 수행한다.
Alternative Courses of Events	N/A
Exceptional Courses of Events	계산에 실패한 경우 다시 진행한다. 사용자가 취소하는 경우 cancel을 진행한다.

2041 Design Real Use Cases

Use Case	7. Prepayment
Actor	None
Purpose	음료의 재고가 존재하지 않아 other vm에서의 선결제를 진행한다.
Overview	음료의 재고가 존재하지 않아 other vm에서의 선결제를 진행한다.
Type	Evident
Cross Reference	Functions: R 3.2 Use Cases:7. Guide other machine, 4. Cancele
Pre-Requisites	Guide other machine을 통해 other vm을 안내 받음
Typical Courses of Events	(U): User, (M): Manager, (S): System, (O): other vm 1.(S): card번호를 요청한다. 2.(U): card번호를 입력한다. 3.(S): card번호에 대한 checkcard를 수행한다 4.(S): checkcard 반환값이 성공인 경우 Create authentication code를 수행한다.
Alternative Courses of Events	사용자는 Cancele을 진행 할 수 있다.
Exceptional Courses of Events	선결제 진행중 (O)의 음료 재고 소진시 Cancele을 진행한다.

2041 Design Real Use Cases

Use Case	8. Read Prepayment authentication code
Actor	None
Purpose	인증코드를 확인한다.
Overview	인증코드를 확인한다.
Type	Evident
Cross Reference	Functions: R 3.3 Use Cases: 1. Select mode
Pre-Requisites	Select mode에서 선결제 수령 메뉴를 선택함
Typical Courses of Events	(U): User, (M): Manager, (S): System, (O): other vm 1. (S) : (U) 에게 인증코드 입력 화면을 보여준다. 2. (U) : User가 인증코드를 입력한다. 3. (S) :입력된 인증 코드에 대한 check authentication code 수행. 4. (S): check authentication 반환값 확인 후 Delete authentication code와 item out 수행.
Alternative Courses of Events	N/A
Exceptional Courses of Events	4의 반환값이 NULL인 경우 1부터 다시 시작한다.

2041 Design Real Use Cases

Use Case	9. Check item stock
Actor	N/A
Purpose	특정 음료의 재고를 확인한다.
Overview	사용자가 선택했거나, msg에 의해 요청받은 특정 음료의 재고를 확인한다.
Type	Hidden
Cross Reference	Functions: R 4.1 Use Cases: 3. select item, 5. msg request
Pre-Requisites	Case 1. 사용자가 음료를 선택한다. (select item) Case 2. other vm으로부터 msg request를 받는다.
Typical Courses of Events	(U):User, (M): Manager, (S): System, (O): other vm 1. (S): 선택된 음료 코드의 재고를 확인한다. 1.1 (S): 재고가 있는 경우 Normal payment를 수행한다. 1.2 (S): 재고가 없는 경우 msg request를 통해 (O)의 재고를 확인한다. 1.3 (S): msgReturn중 가까운 vm을 안내한다. 2. (S): msgRequest로 전달받은 음료 코드의 개수만큼 검사한다. 2.1. (S): 검사결과가 유효하면 msgReturn을 진행한다.
Alternative Courses of Events	N/A
Exceptional Courses of Events	N/A

2041 Design Real Use Cases

Use Case	10. Read Manager authentication code
Actor	Manager
Purpose	Manager가 매니저 모드를 실행한다.
Overview	Manager가 매니저 모드를 실행할 때 인증을 거친다.
Type	Evident
Cross Reference	Functions: R 5.1 Use Cases: 13. Manage stock, 1. Select mode
Pre-Requisites	Select mode에서 매니저 모드를 선택함
Typical Courses of Events	(U): User, (M): Manager, (S): System, (O): other vm 1. (S) : Manager에게 인증 코드 입력 화면을 보여준다. 2. (M) : Manager가 인증 코드를 입력한다. 3. (S): Manager 인증코드를 확인한다. 4. (S) : Manage 할 수 있는 화면을 보여준다.
Alternative Courses of Events	N/A
Exceptional Courses of Events	취소시 selectMode로 돌아간다.

2041 Design Real Use Cases

Use Case	11. Manage stock
Actor	Manager
Purpose	음료의 개수를 추가한다.
Overview	음료의 개수를 추가한다.
Type	Evident
Cross Reference	Functions: R 5.2 Use Cases: 12. Read Manager authentication code, 1. Select mode
Pre-Requisites	Manager access를 성공함
Typical Courses of Events	(U): User, (M): Manager, (S): System, (O): other vm 1. (S): (M)에게 화면을 보여준다. 2. (M): 추가할 음료의 코드와 개수를 입력한다.
Alternative Courses of Events	N/A
Exceptional Courses of Events	N/A

2042 Define Reports, UI, and Storyboards

Select mode

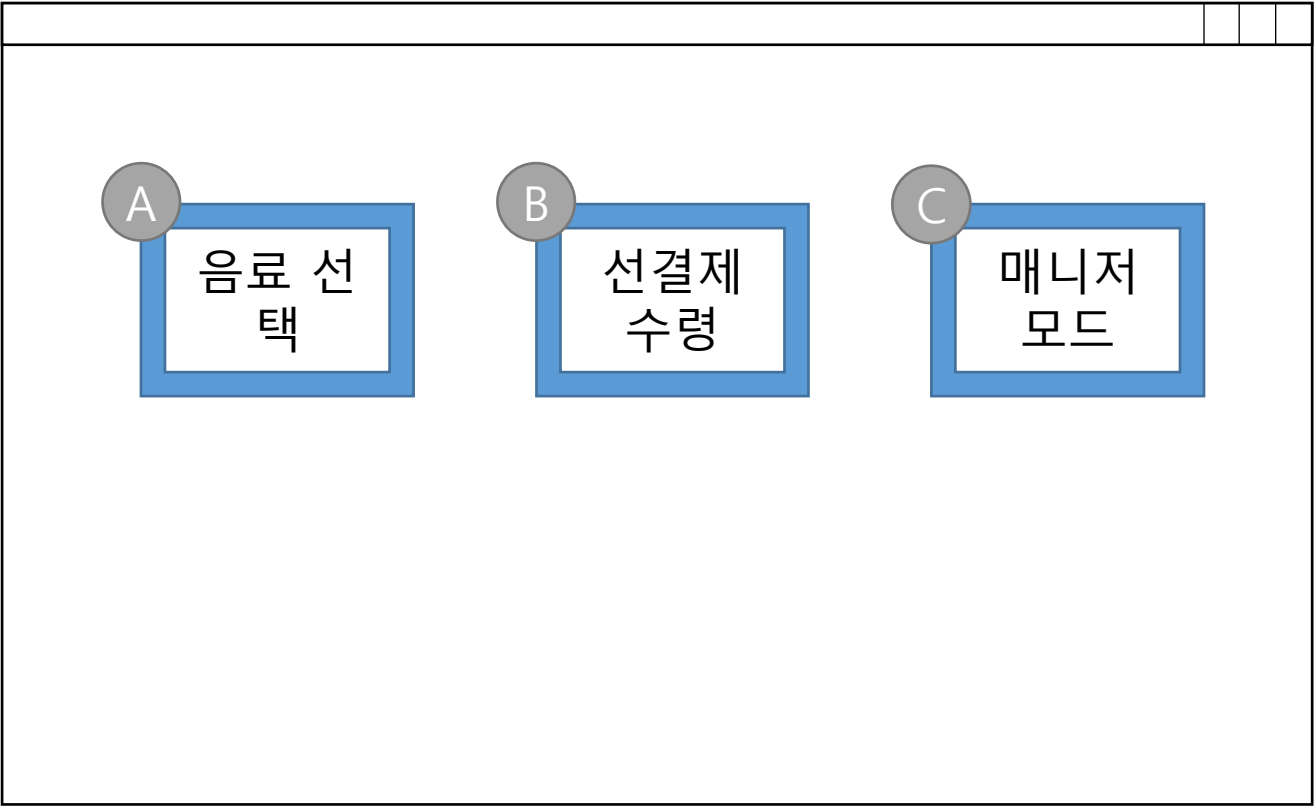

2042 Define Reports, UI, and Storyboards

Set up

The image shows a window titled "Set up" containing a form with six input fields and one button. Each input field has a label on the left and a "V" button on the right. The fields are labeled with letters A through F. The labels are: "Other DVM ID", "Manager ID", "카드 번호", "카드 잔액", "음료 코드", and "음료 개수". The "OK" button is located at the bottom center of the form.

Label	Field ID	Field Type	Action
Other DVM ID	A	Text	V
Manager ID	B	Text	V
카드 번호	C	Text	V
카드 잔액	D	Text	V
음료 코드	E	Text	V
음료 개수	F	Text	V
		OK (G)	

2042 Define Reports, UI, and Storyboards

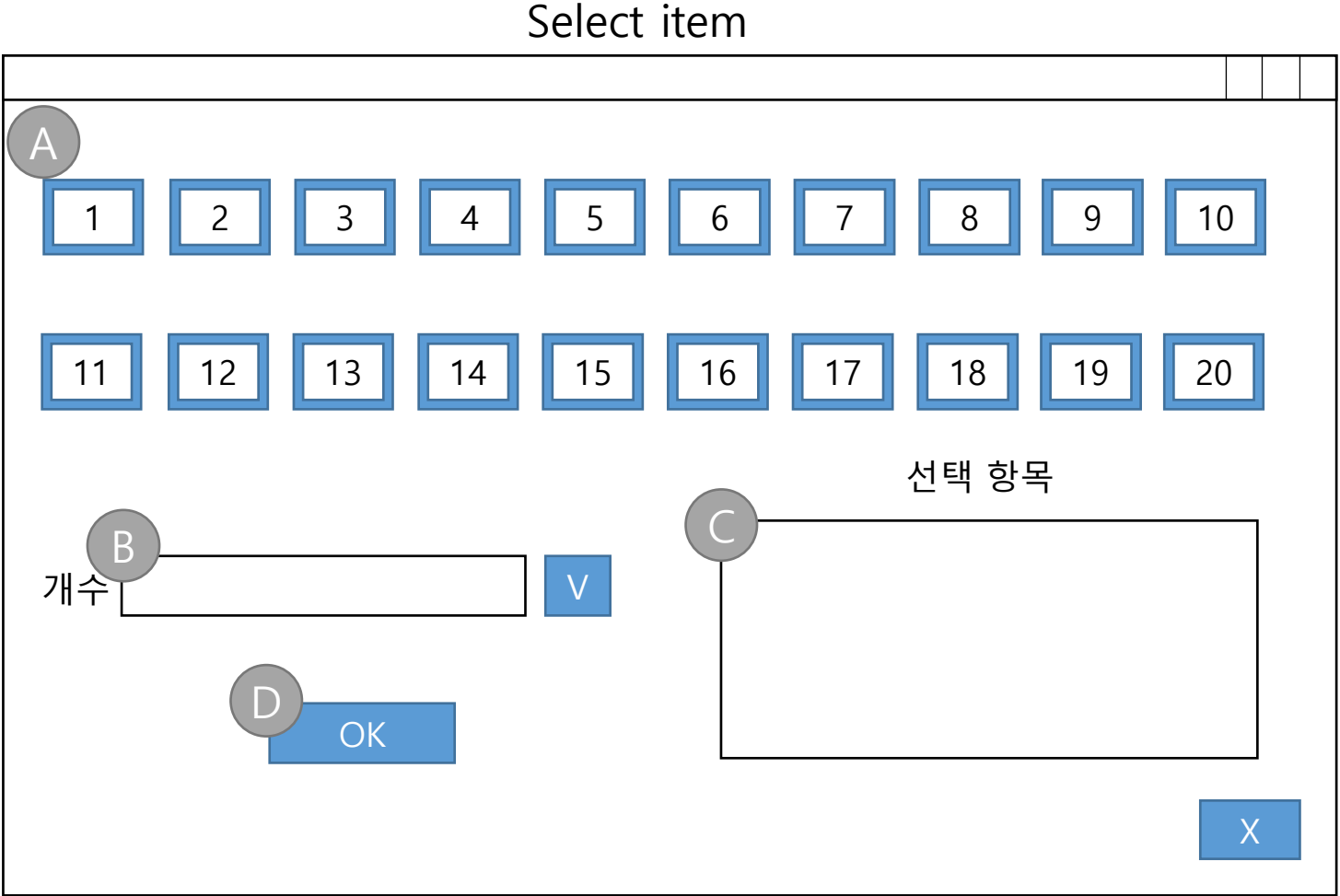

2042 Define Reports, UI, and Storyboards

Guide other machine

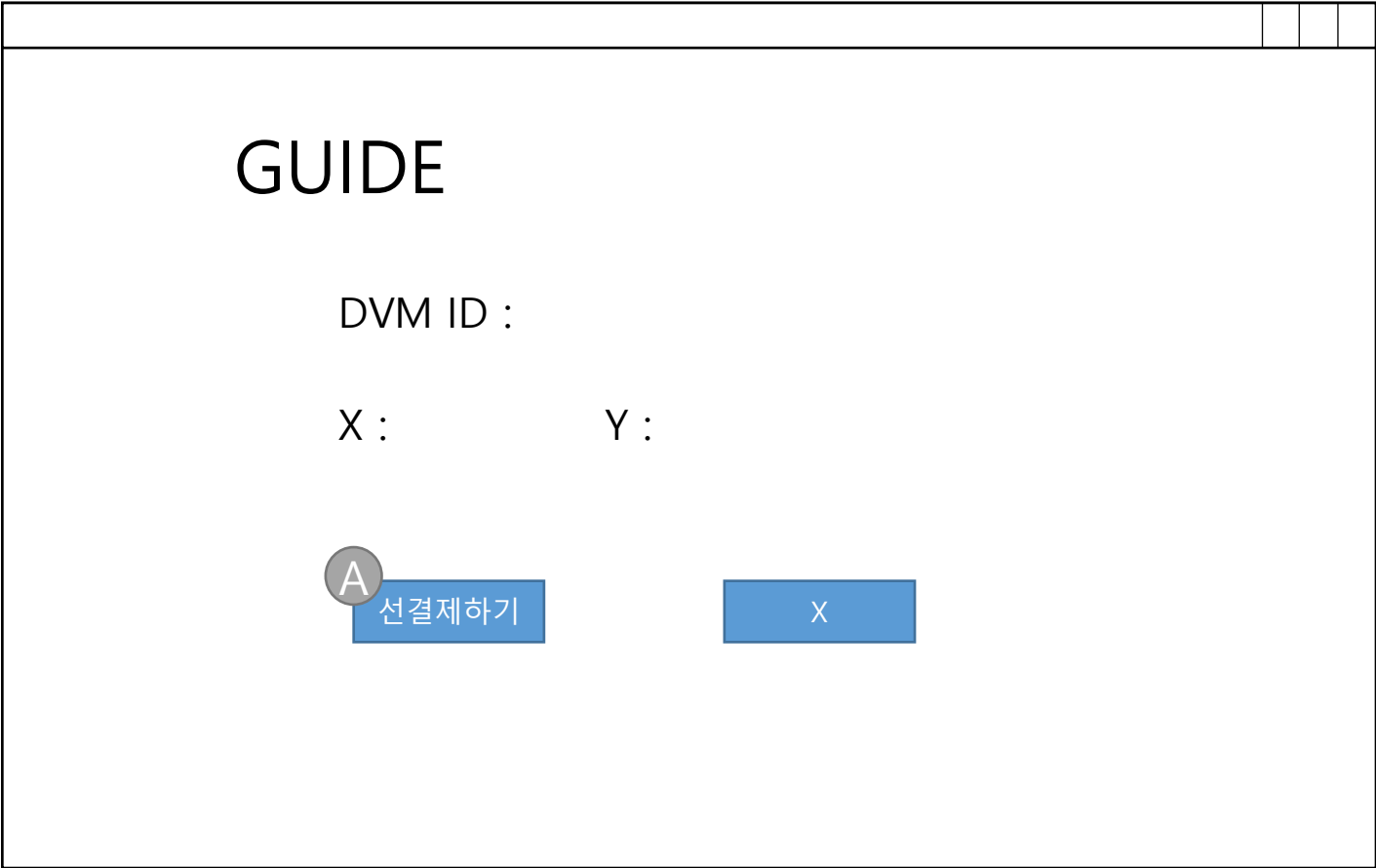

2042 Define Reports, UI, and Storyboards

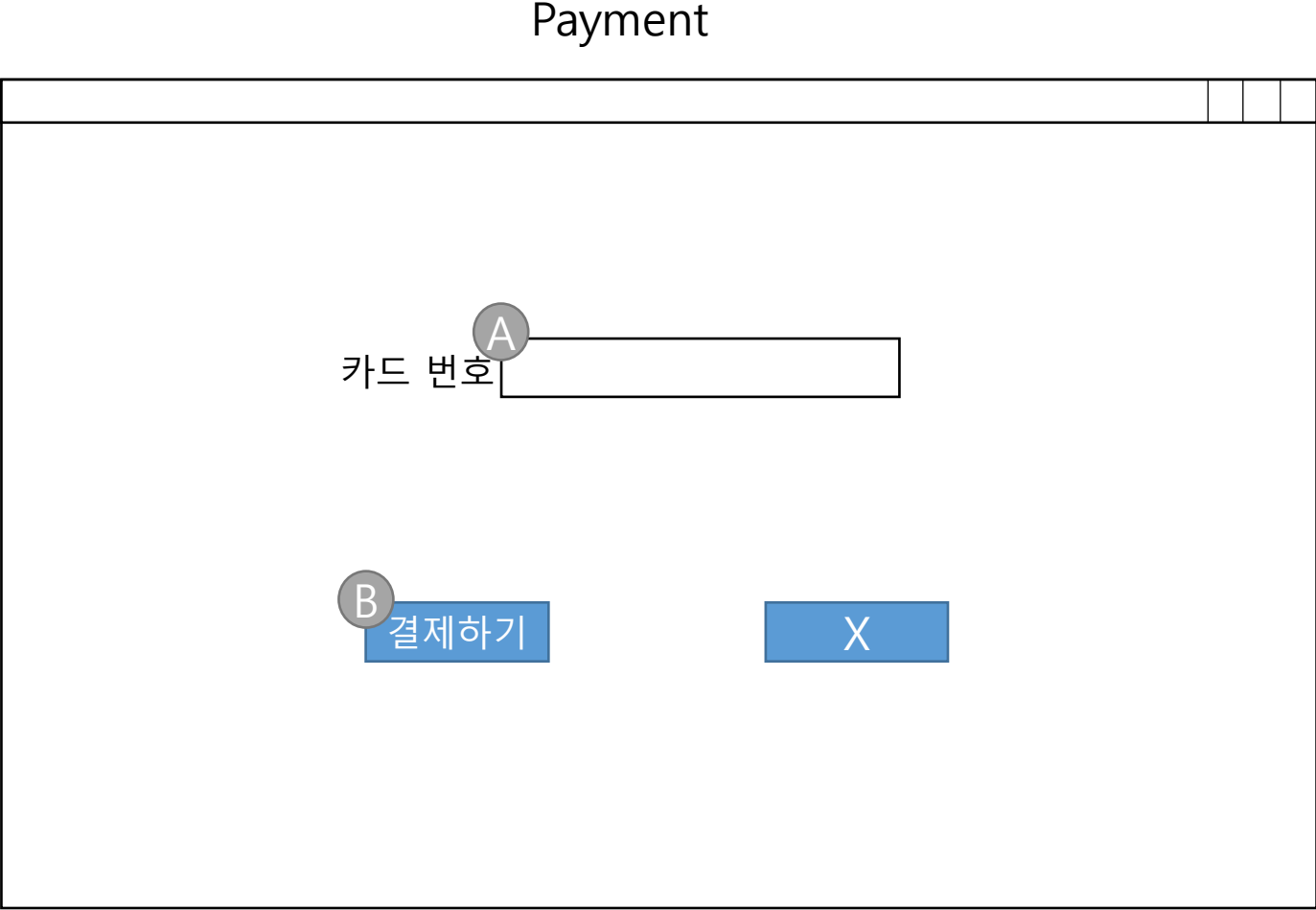

2042 Define Reports, UI, and Storyboards

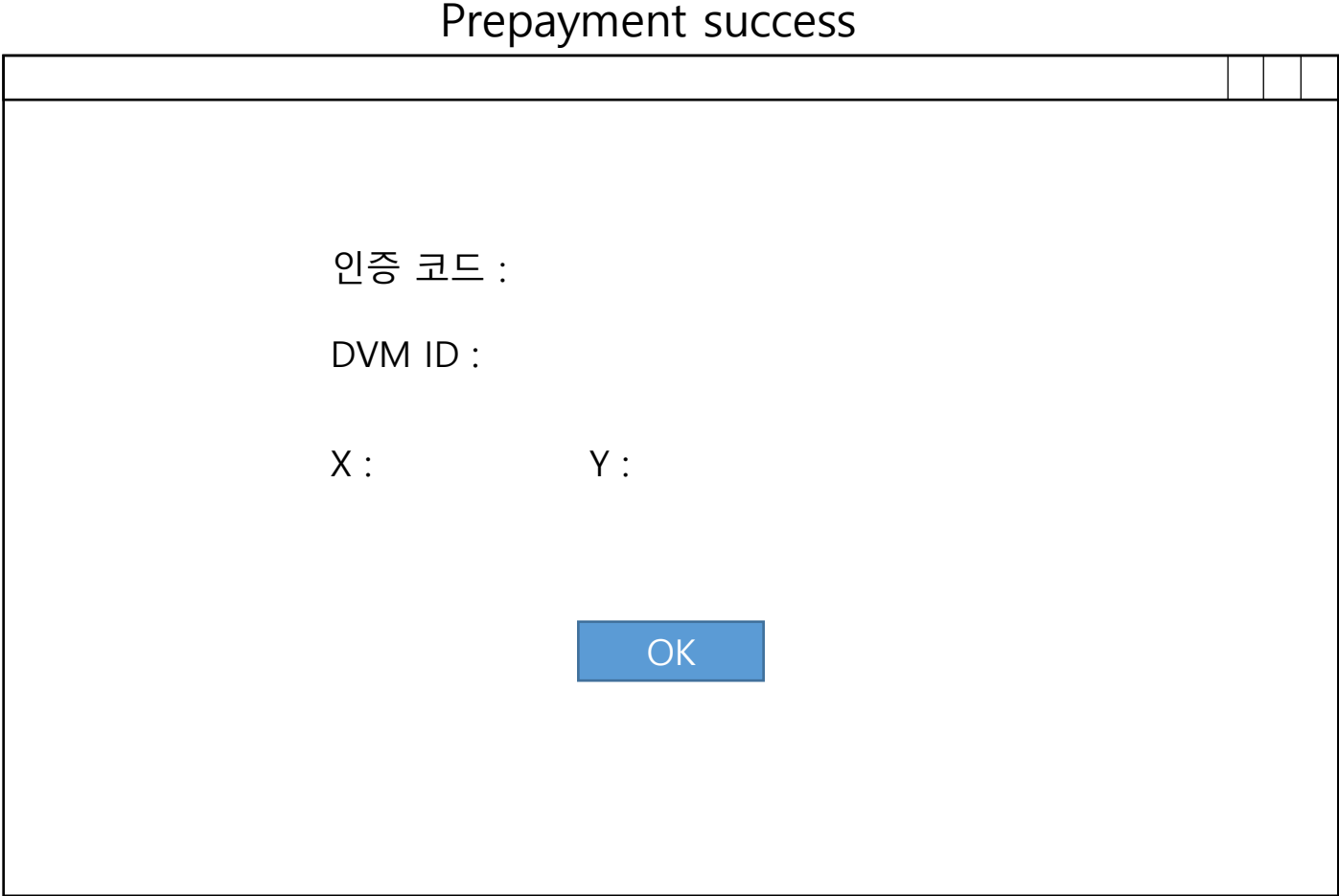

2042 Define Reports, UI, and Storyboards

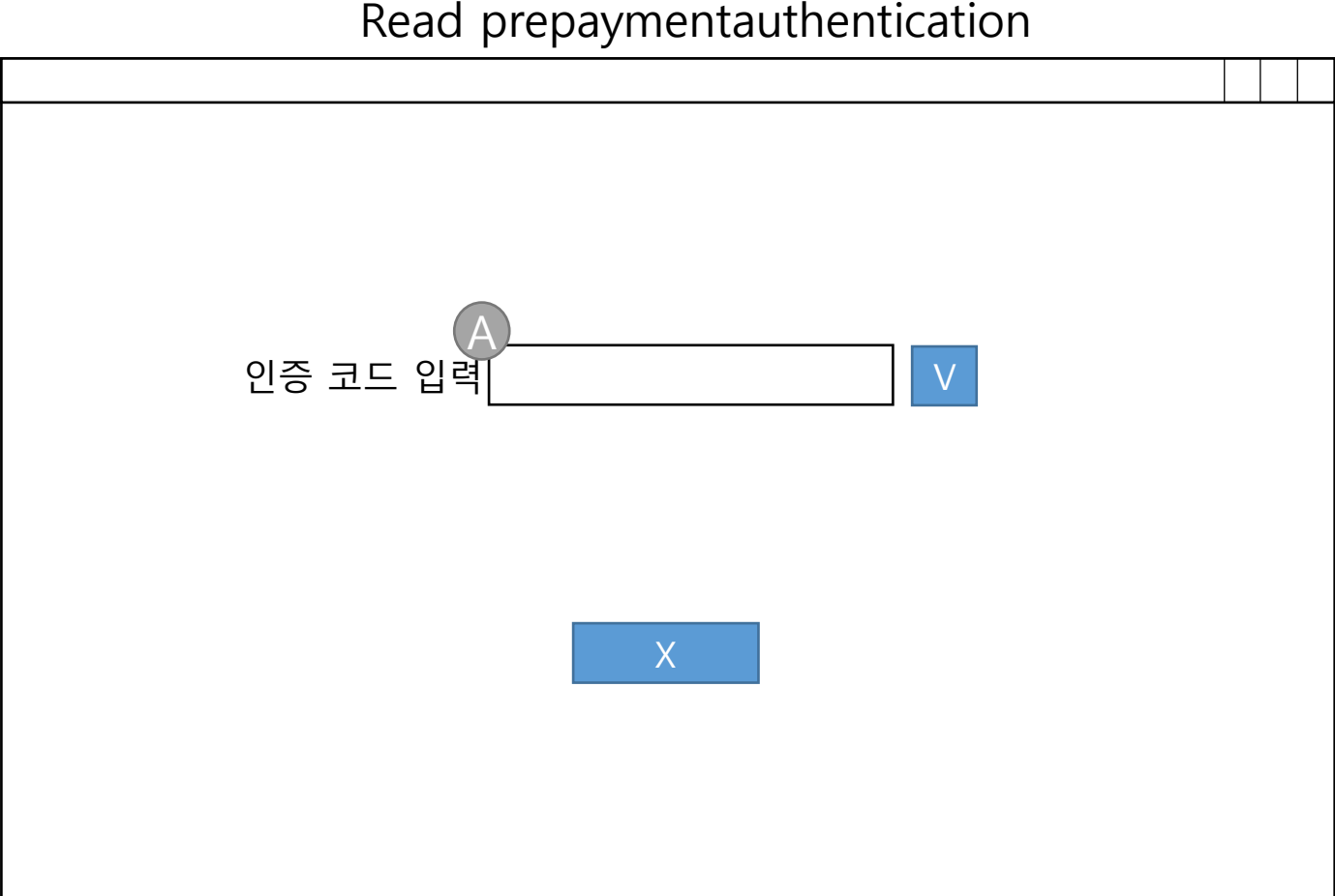

2042 Define Reports, UI, and Storyboards

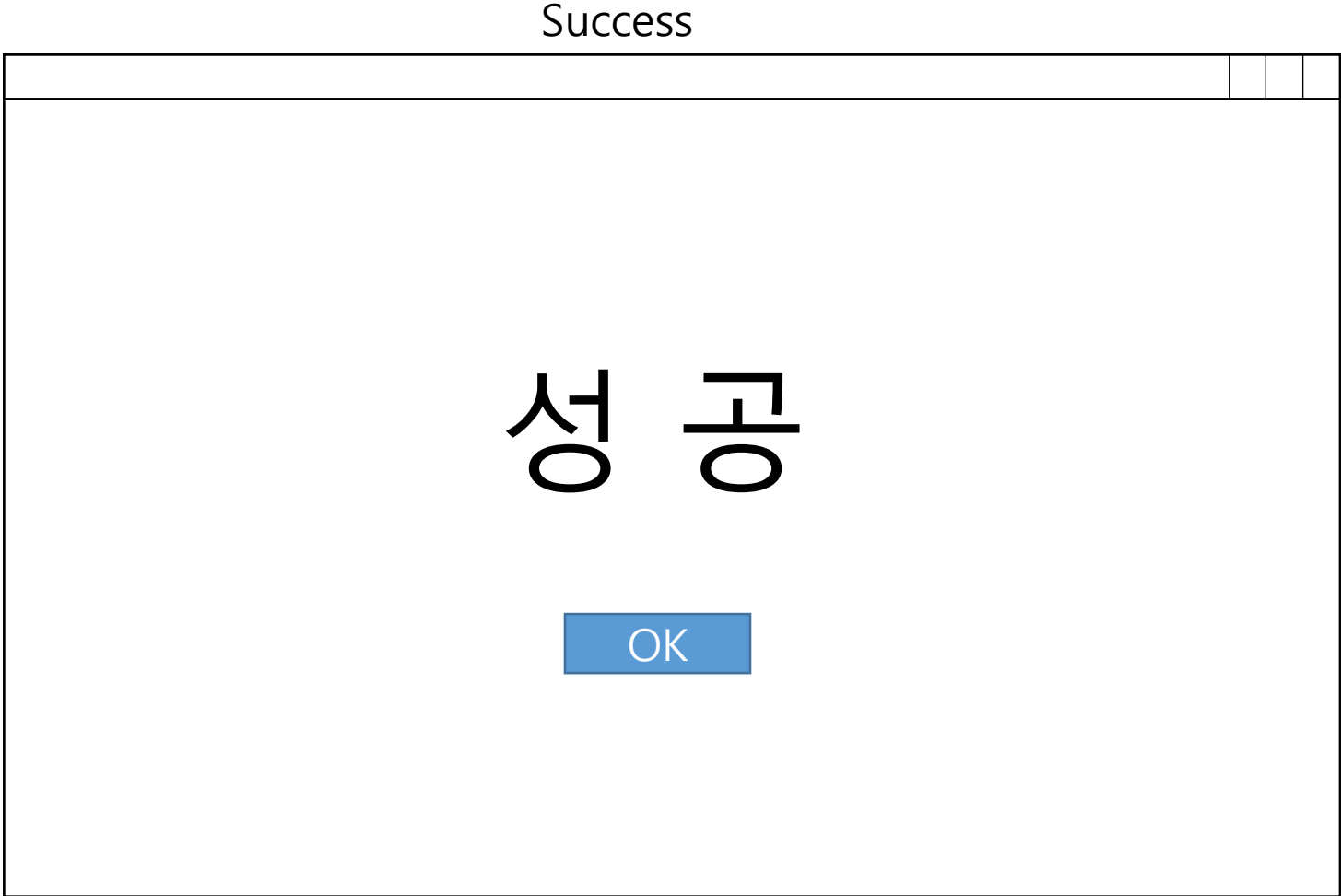

2042 Define Reports, UI, and Storyboards

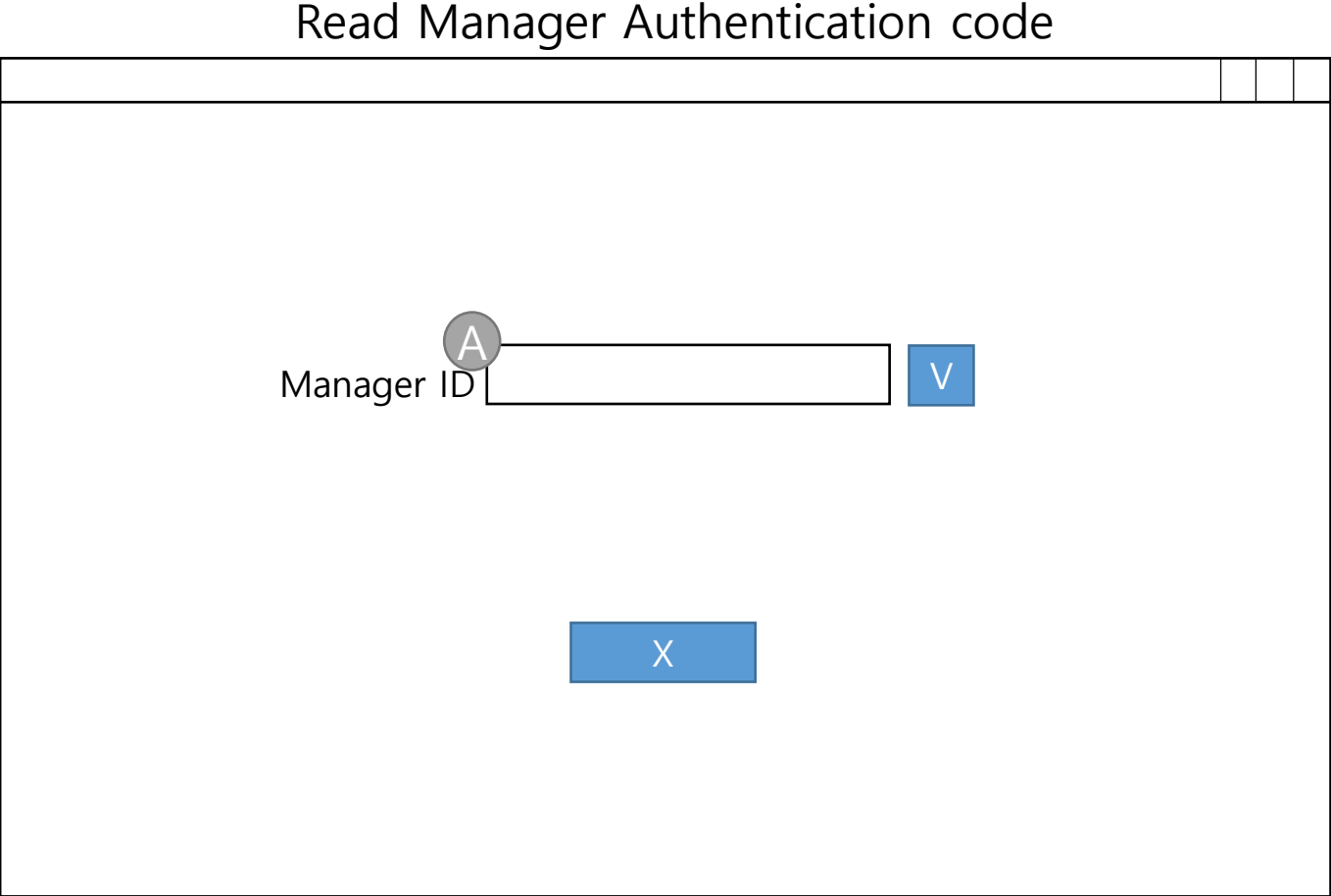

2042 Define Reports, UI, and Storyboards

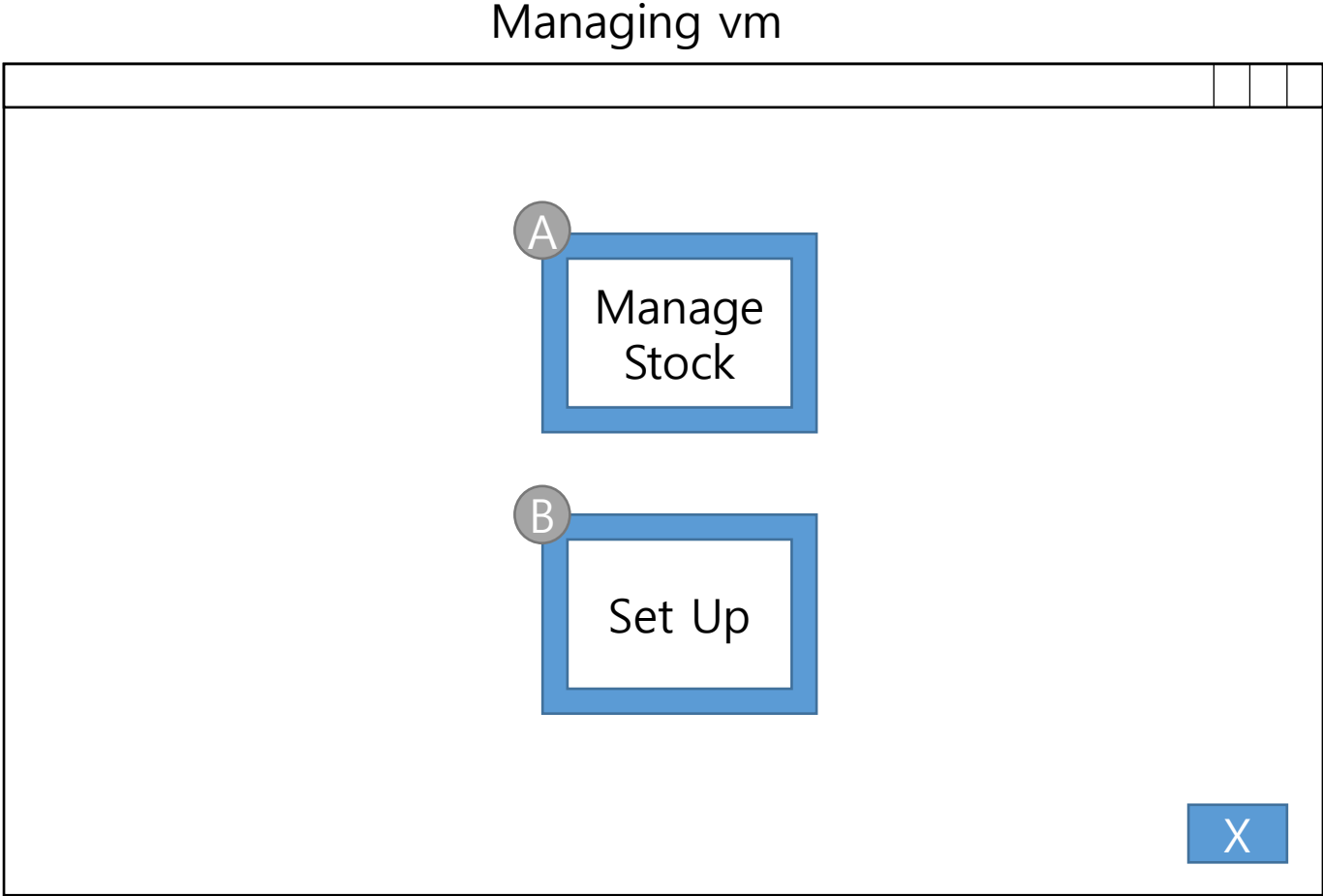

2042 Define Reports, UI, and Storyboards

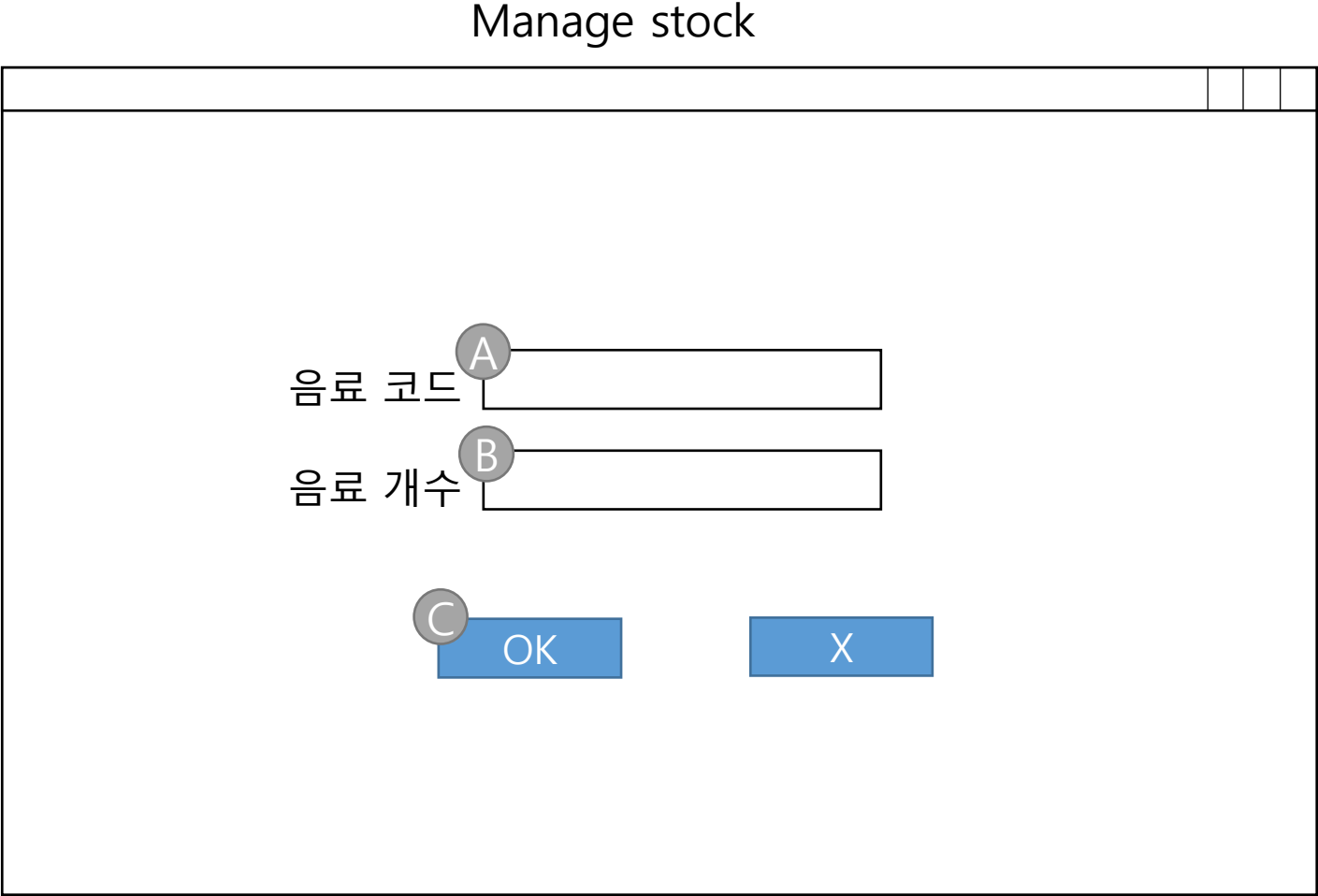

2044 Define System Sequence Diagrams

01. Select mode

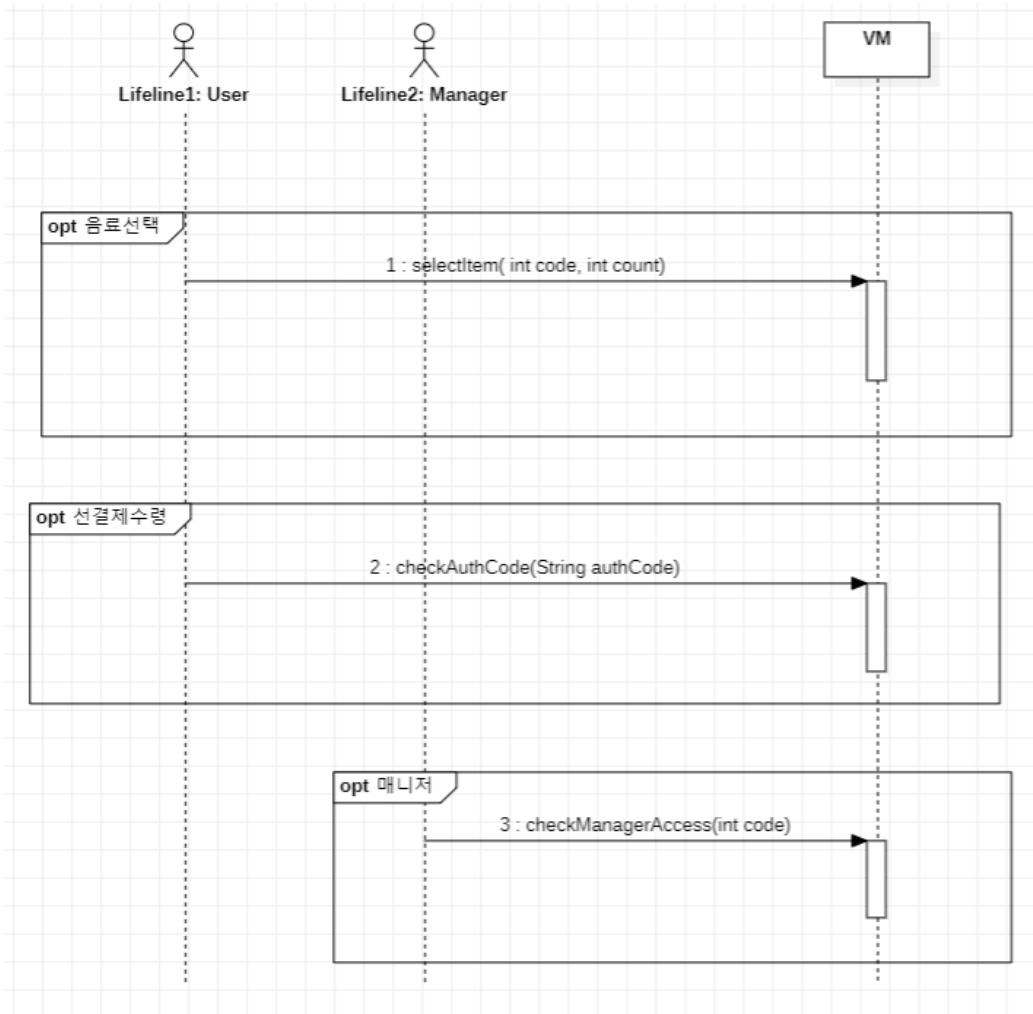

02. Set up

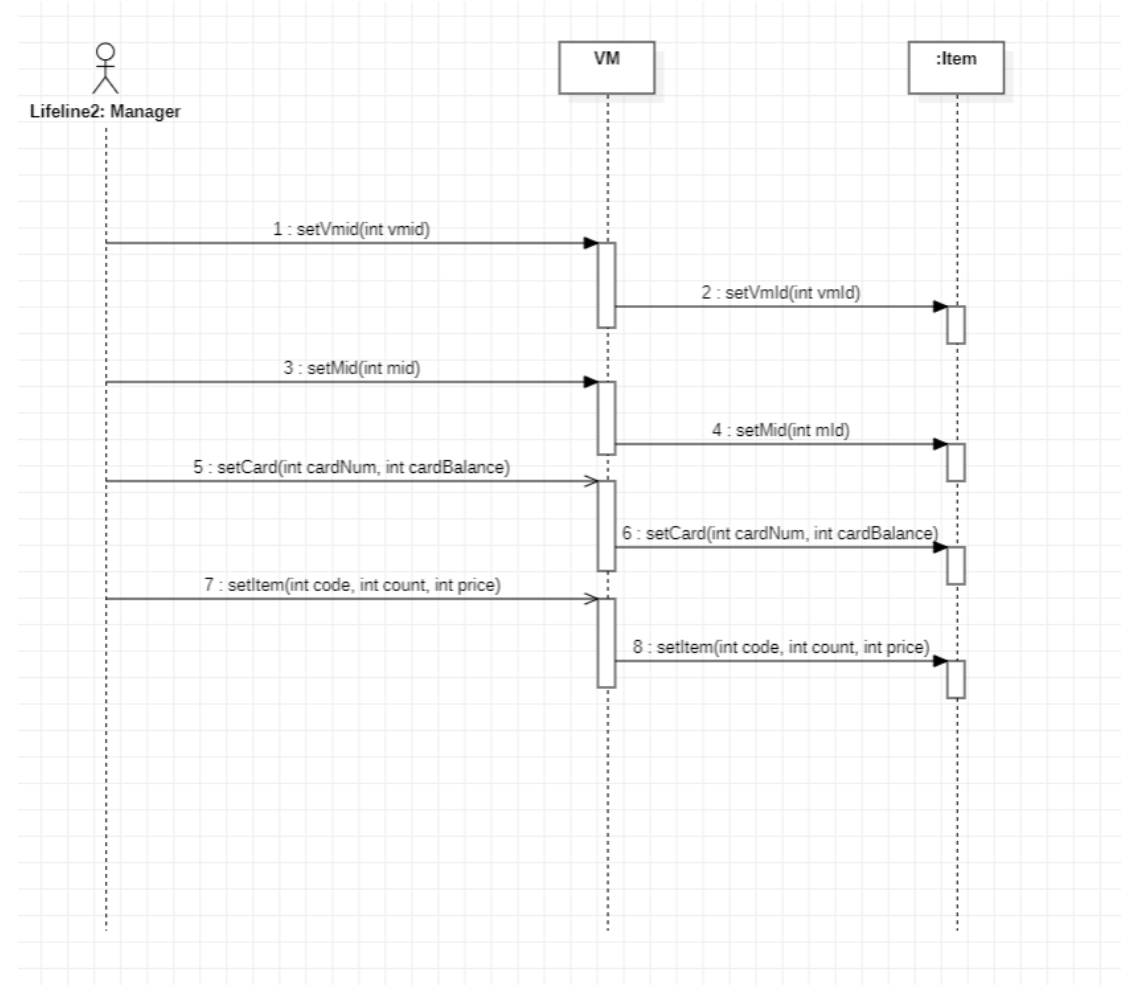

2044 Define System Sequence Diagrams

03. Check item stock

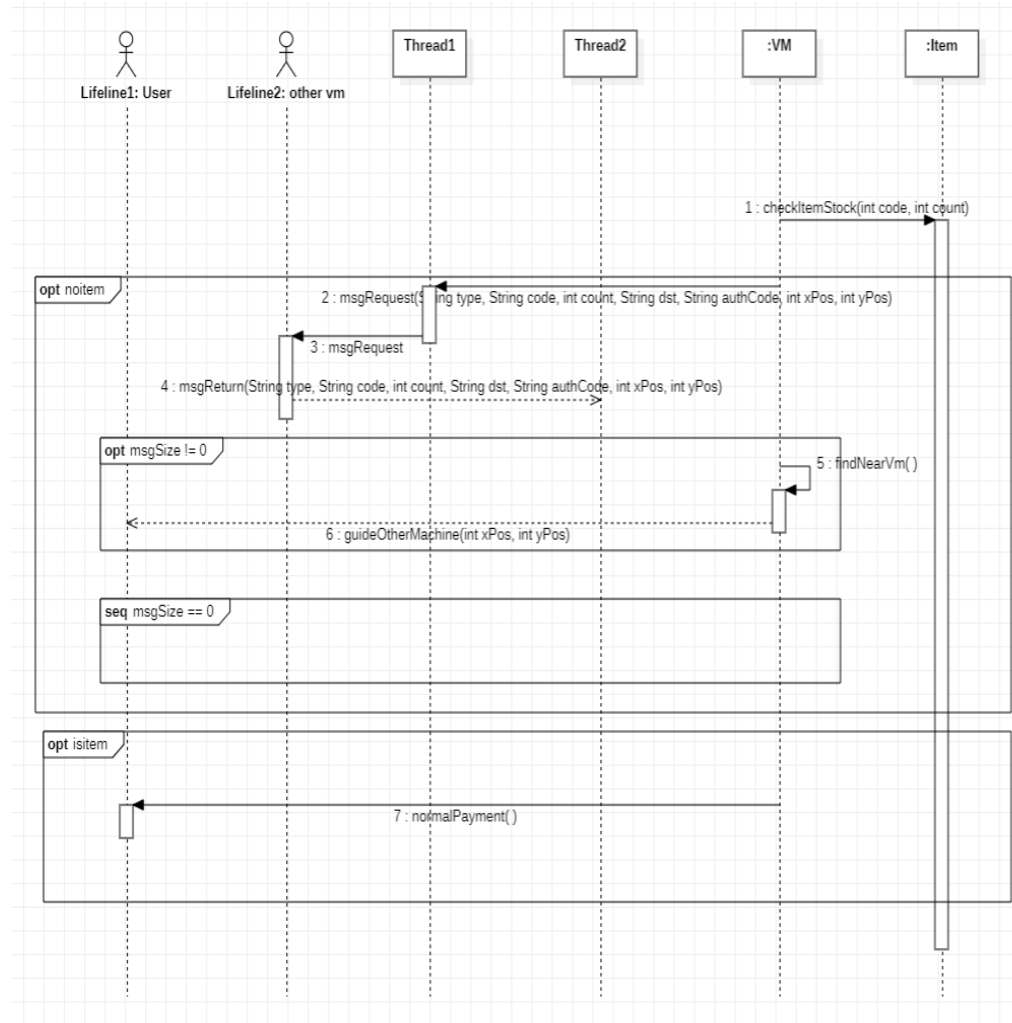

04. msg Request & Return

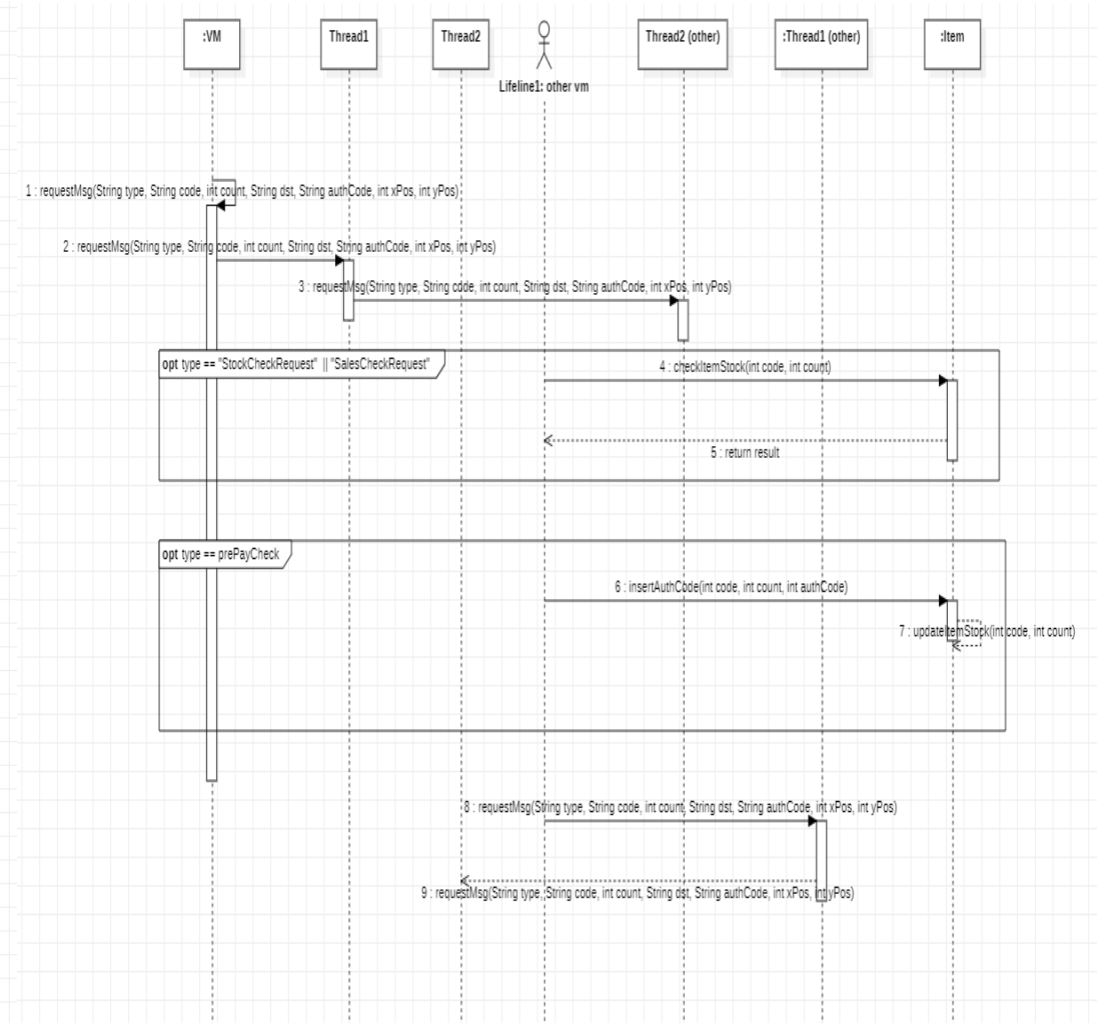

2044 Define System Sequence Diagrams

06. Normal payment

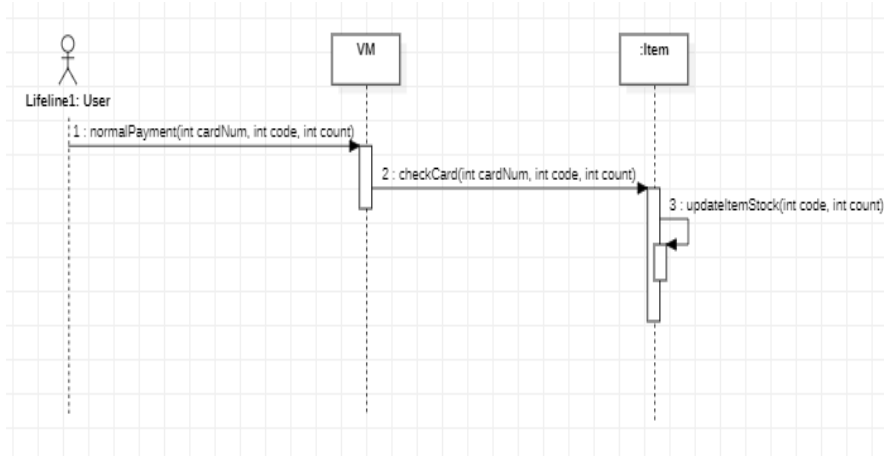

07. PrePayment

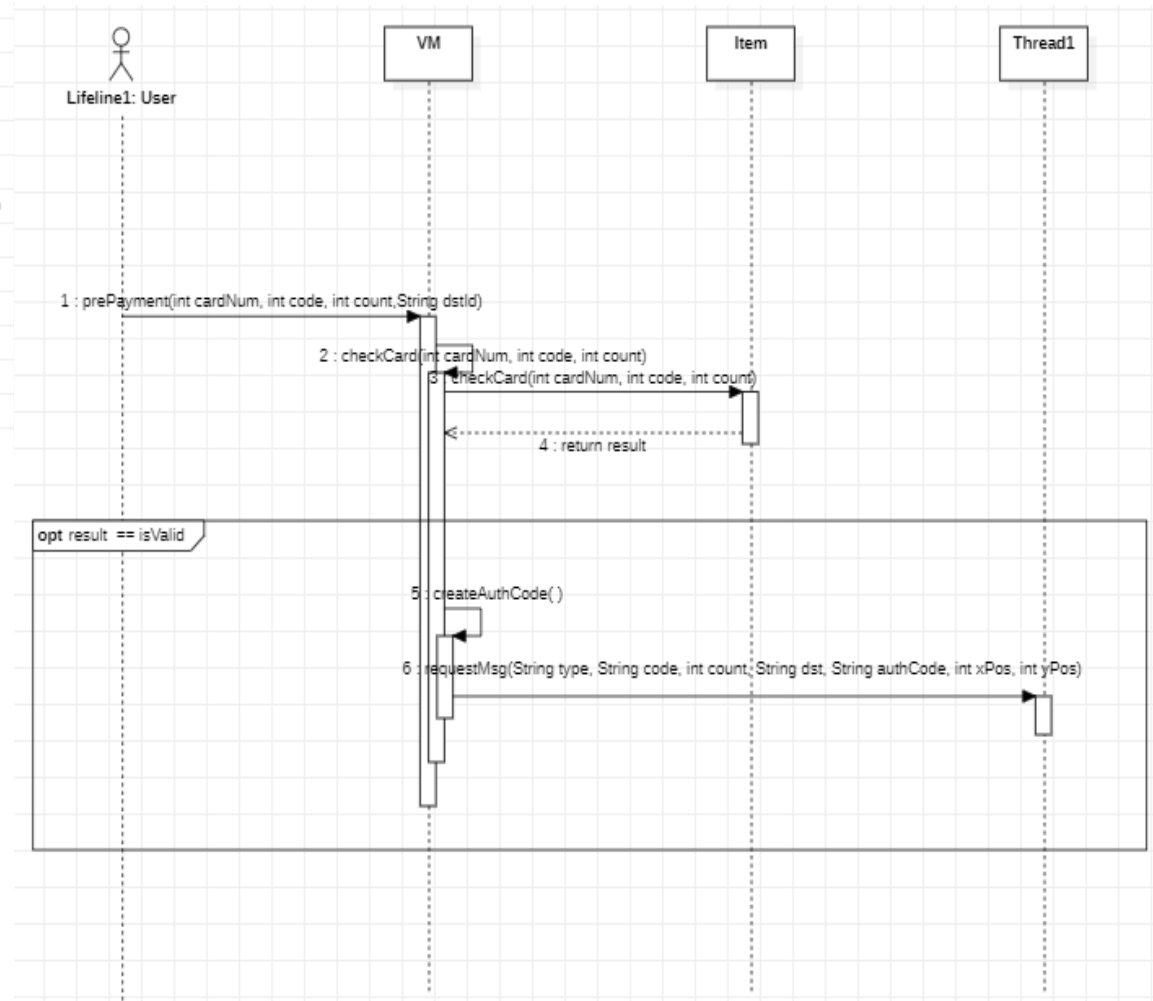

2044 Define System Sequence Diagrams

08. Read prepayment authentication code

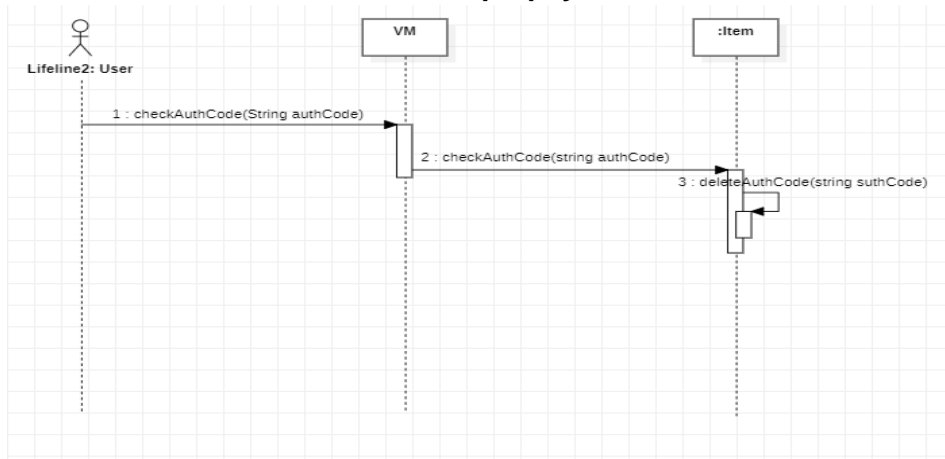

09. Read manager authentication code

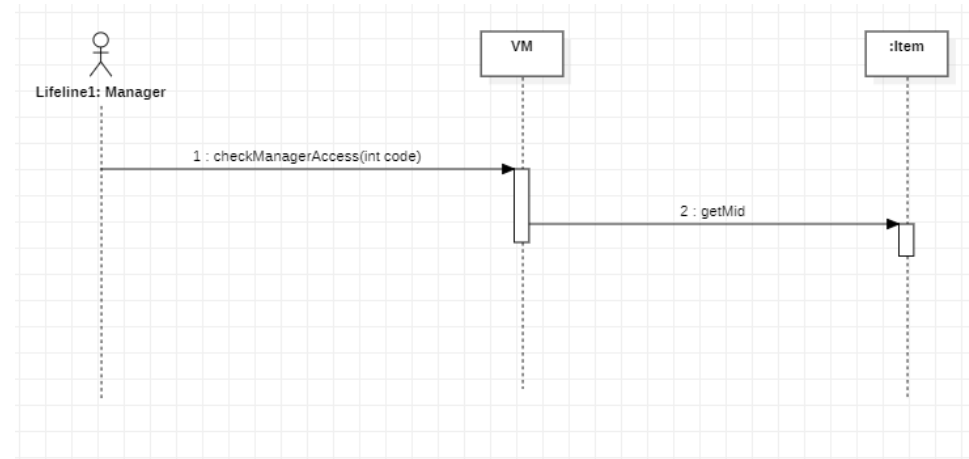

10. Manage stock

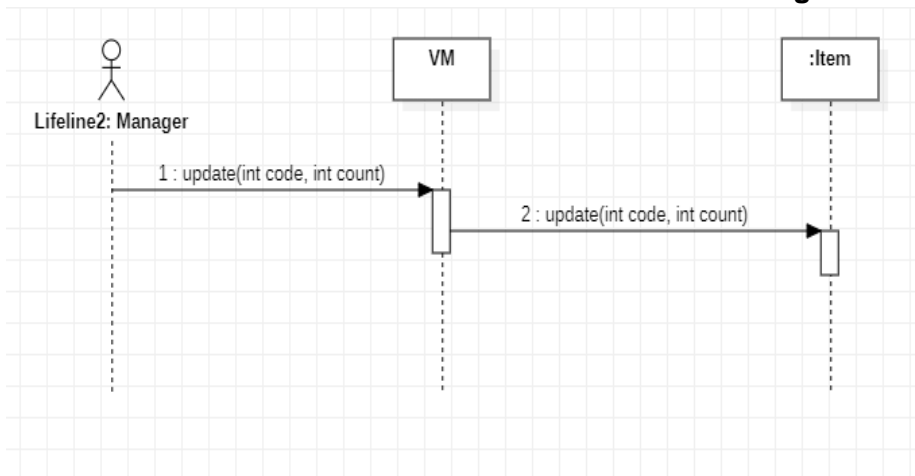

2045 Define Design Class Diagram

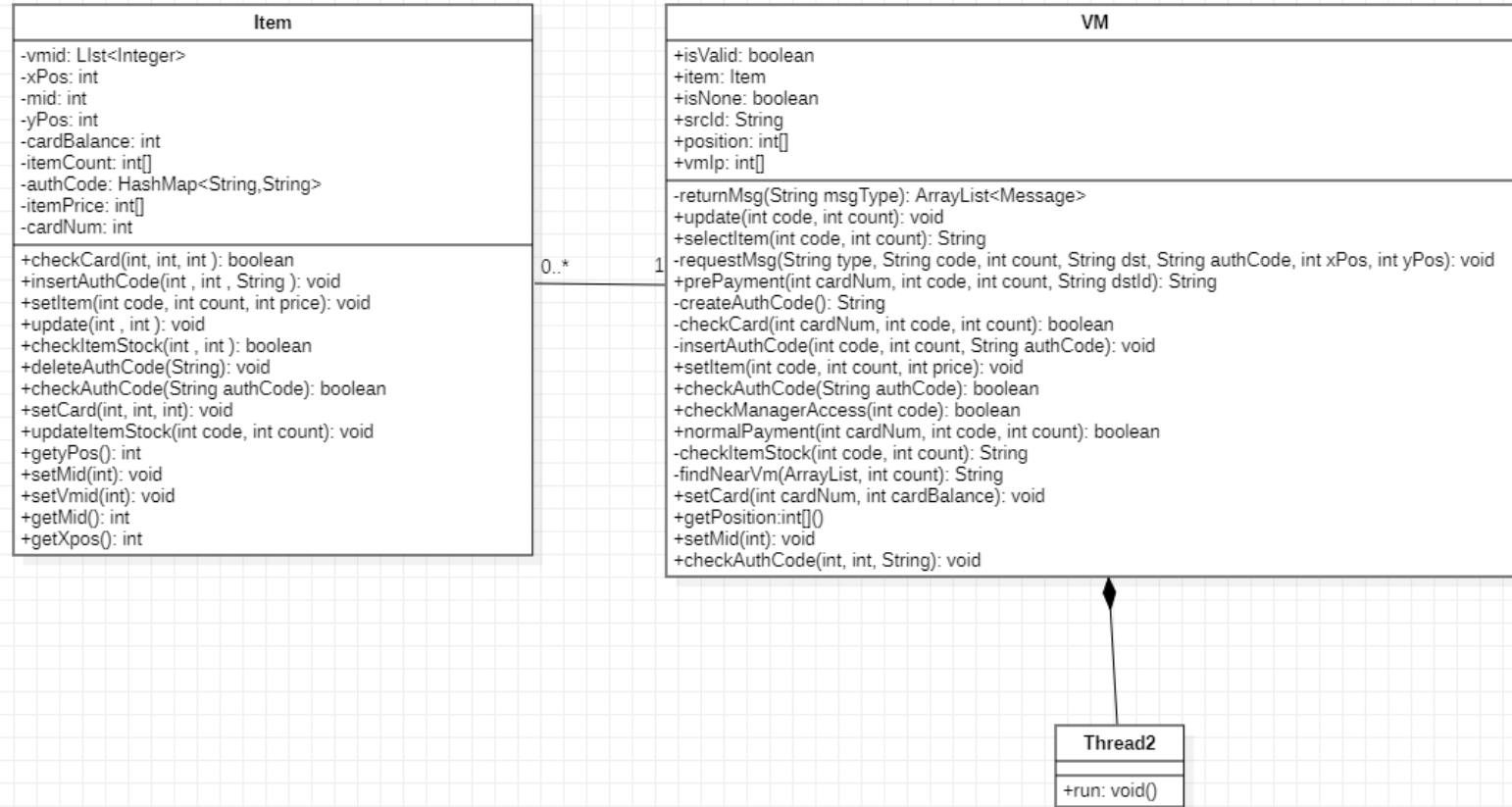

2046 Design Traceability Analysis

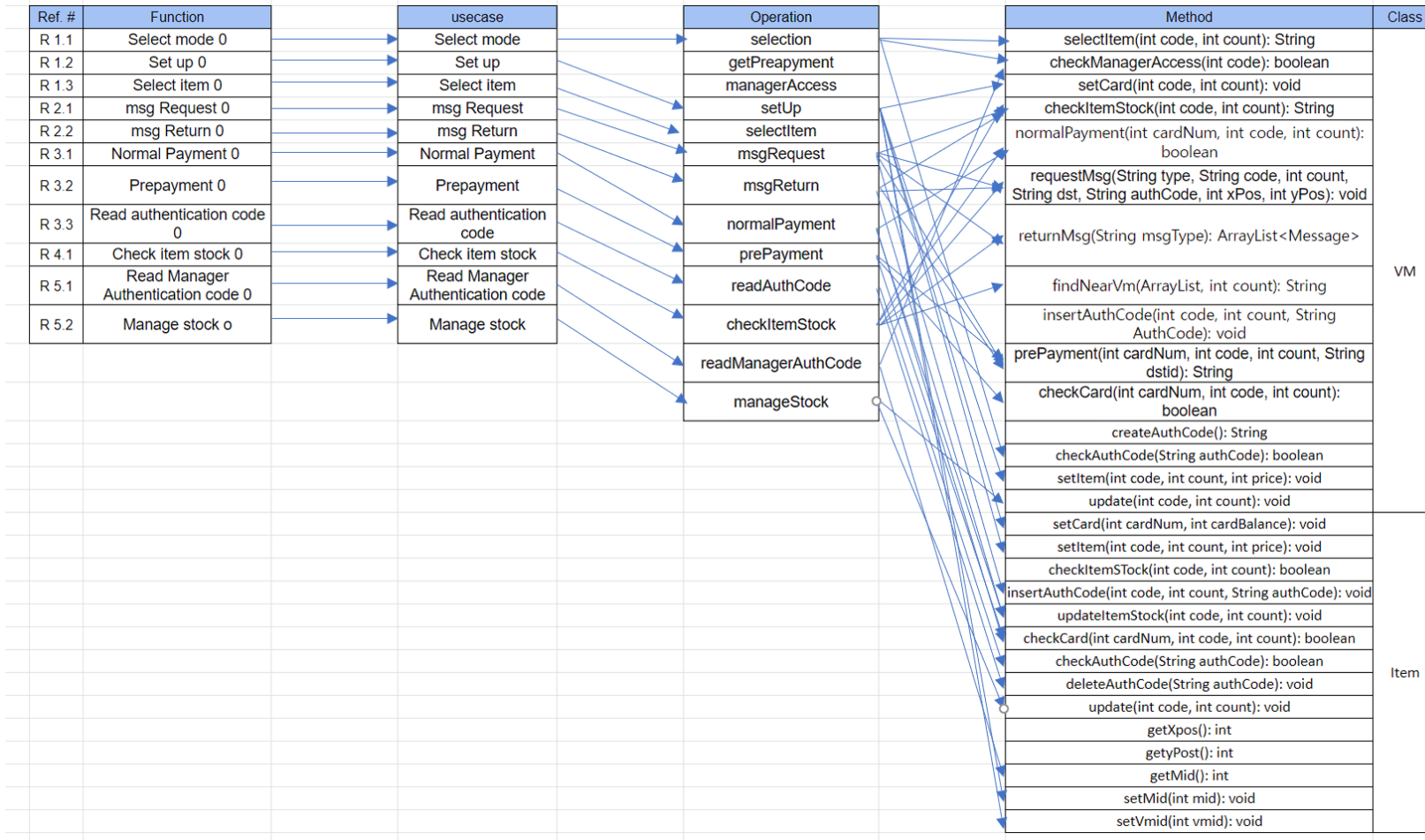

Q&A

201711310 변건우

202011313 손윤환

202014186 오상희

201912698 이현규